

DESCRIPTION

The GLF72511 Load Switch is a fully integrated 2A NMOS load switch with I_QSmart™ advanced technology. The device is targeted for the mobile computing and data storage markets as a high performance, low cost solution for load switch applications.

The GLF72511 has a constant low on-resistance of 27 mΩ at room temperature. The fixed rise time helps prevent undesirable inrush current when turned on and the internal EN pin pulldown resistor ensures the device remains in the shutdown mode when disabled. In shutdown mode the GLF72511 draws only 6 nA typical at 3.6 V input supply voltage.

The GLF72511 is available in a wafer level chip scale package (WLCSP) measuring 0.97 mm x 0.97 mm x 0.55mm with a 0.5 mm pitch. This allows the user to save board space and increase cost savings.

FEATURES

- Supply Voltage Range : 0.8 V to 3.6 V
- Low R_{ON} : 27 mΩ Typ at Supply Voltage Range
- I_{OUT} Max : 2 A
- Ultra-Low I_Q :
 - 50 nA Typ at 0.8 V_{IN}
 - 60 nA Typ at 1.0 V_{IN}
 - 80 nA Typ at 1.2 V_{IN}
- Integrated Slew Rate Control Driver
- Internal EN Pull-Down Resistor
- Integrated Output Discharge Switch : GLF72511
- HBM : 6 kV, CDM : 2 kV
- Ultra-Small : 0.97mm x 0.97mm x 0.55mm Wafer Level Chip Scale Package

APPLICATIONS

- Wearables
- Data Storage, SSD
- Low Power Subsystems

PACKAGE

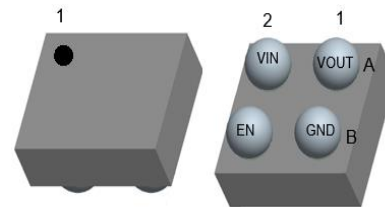

0.97 mm x 0.97 mm x 0.55 mm WLCSP

APPLICATION DIAGRAM

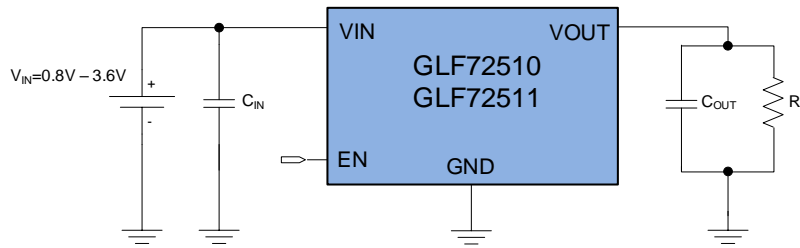

FUNCTIONAL BLOCK DIAGRAM

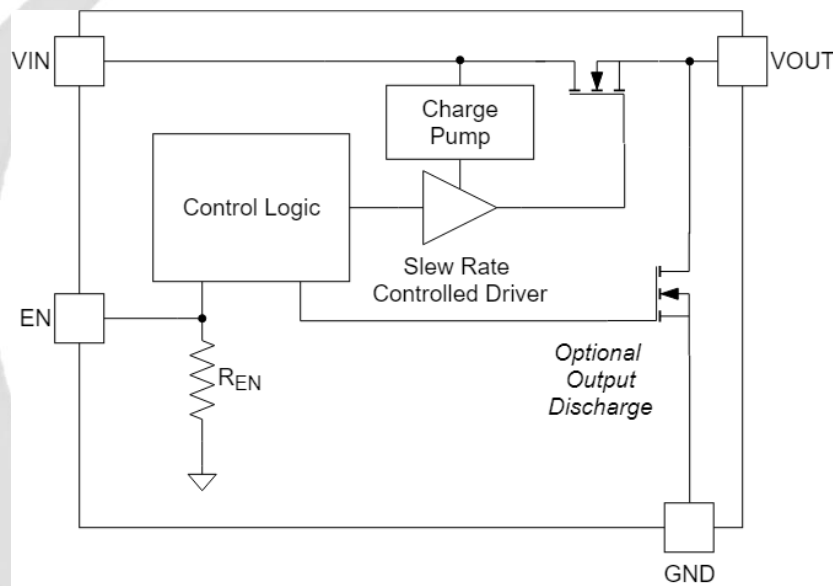
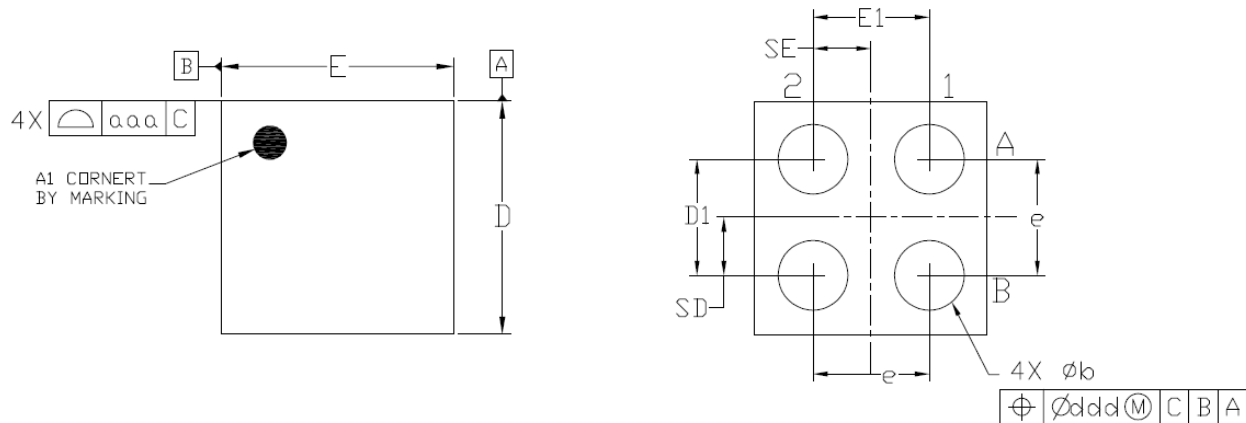

Figure 1. Functional Block Diagram

PACKAGE OUTLINE



Dimensional Ref.			
REF.	Min.	Nom.	Max.
A	0.500	0.550	0.600
A1	0.225	0.250	0.275
A2	0.275	0.300	0.325
D	0.960	0.970	0.985
E	0.960	0.970	0.985
D1	0.450	0.500	0.550
E1	0.450	0.500	0.550
b	0.260	0.310	0.360
e	0.500 BSC		
SD	0.250 BSC		
SE	0.250 BSC		
Tol. of Form&Position			
aaa	0.10		
bbb	0.10		
ccc	0.05		
ddd	0.05		

Notes

1. ALL DIMENSIONS ARE IN MILLIMETERS (ANGLES IN DEGREES).
2. DIMENSIONING AND TOLERANCING PER ANSI Y14.5M-1994.