

DESCRIPTION

The GLF73910 / GLF73911 is an I_QSmart™ ultra-efficient, full battery protection switch with an accurate over charge voltage, over discharge voltage, and short circuit protection for lithium-ion/Polymer battery safety.

The over charge and discharge voltage protections keep a rechargeable battery working within the desired safe operating condition. When the battery is charged past the over voltage detection level, the GLF73910 / GLF73911 switch opens in a preset delay time.

As the battery voltage decreases below the over discharge detection voltage level, the GLF73910 / GLF73911 switch is turned off immediately to cut off the battery power rail, consuming an ultra-low leakage current (I_{SD}) to save the battery. In addition, when the load current reaches the I_{SC} short circuit protection level, the GLF73910 / GLF73911 switch is turned off and will maintain the off state to avoid any serious damage to system. The short circuit delay time avoids any false trigger which might open the switch.

When a charged battery cell is connected, the GLF73910 / GLF73911 remains in the off state and consumes an ultra-low leakage current (I_{SD}) until the V_{ON} voltage is applied to VOUT pin. Note that the GLF73910 / GLF73911 is activated only by a V_{ON} voltage from a charger output.

FEATURES

- Over Charge Detection Voltage, V_{OC}
 - 4.35 V_{BAT} : GLF73910-AD01, GLF73910-AD01C
GLF73911-AD01
 - 4.50 V_{BAT} : GLF73910-BD01
 - Monitor V_{BAT} to release V_{OC} : GLF73910
 - Monitor V_{OUT} to release V_{OC} : GLF73911
- Over Discharge Detection Voltage, V_{OD} : 2.80 V_{BAT}
- Load Short Circuit Protection with Delay Time to avoid a false trigger
- Activated by Applying V_{ON} to the VOUT Pin from Charger
- 1.5 A Continuous Charging Current Capability from VOUT to V_{BAT} Pin
- Low R_{ON} : 36 mΩ Typ. @ 3.6 V_{BAT}
- Quiescent Current, I_Q = 720 nA Typ @ 3.6 V_{BAT}
- Shutdown Current, I_{SD}
 - GLF73910: 70 nA Typ @ V_{BAT} < V_{OD}
 - GLF73911: 35 nA Typ @ V_{BAT} < V_{OD}
- Latch-off at Over Discharge Detection and Short Circuit Protection. Apply V_{ON} to VOUT pin to turn on again
- 0 V Battery Charging: GLF73910-AD01C
- 0.4 V Minimum Battery Voltage for Charging
- Reverse Polarity Connection Protection
- Patent Pending Circuit Architecture
- HBM: 8 kV, CDM: 2 kV
- 0.97 mm x 0.97 mm x 0.55 mm Chip Scale Package
4 Bumps, 0.5 mm Pitch

APPLICATIONS

- BLE Wireless Earphone
- Wearables / IoT Devices

PACKAGE

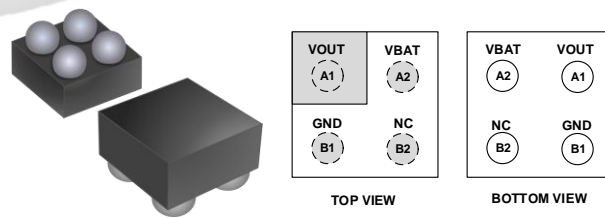

0.97 mm x 0.97 mm x 0.55 mm WLCSP

DEVICE INFORMATION

Part Number	Top Mark	Over Charge Detection, V_{oc}	Over Discharge Detection, V_{od}	Short Circuit Current, I_{sc}	0 V Charging	Package
GLF73910-AD01	CF	4.35 V	2.80 V	0.6 A	NA	0.97 mm x 0.97 mm WLCSP 3000 pieces on 7 inch reel
GLF73910-AD01C	CE	4.35 V	2.80 V	0.6 A	Available	
GLF73910-BD01	CG	4.50 V	2.80 V	0.6 A	NA	
GLF73911-AD01	CH	4.35 V	2.80 V	0.6 A	NA	

APPLICATION DIAGRAM

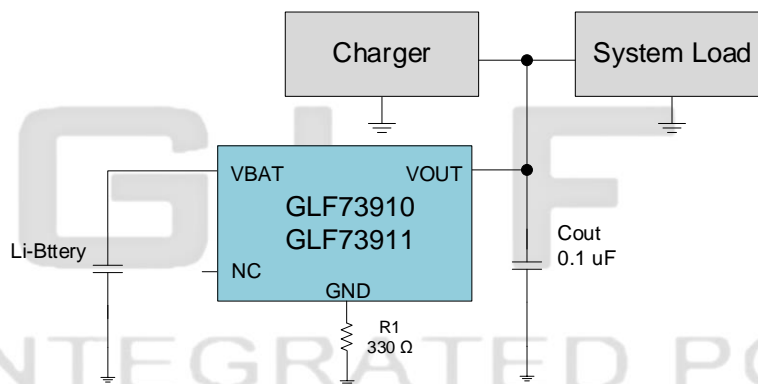

Note: The GLF73910 is activated by applying the V_{ON} to the VOUT pin.

TIMING DIAGRAM

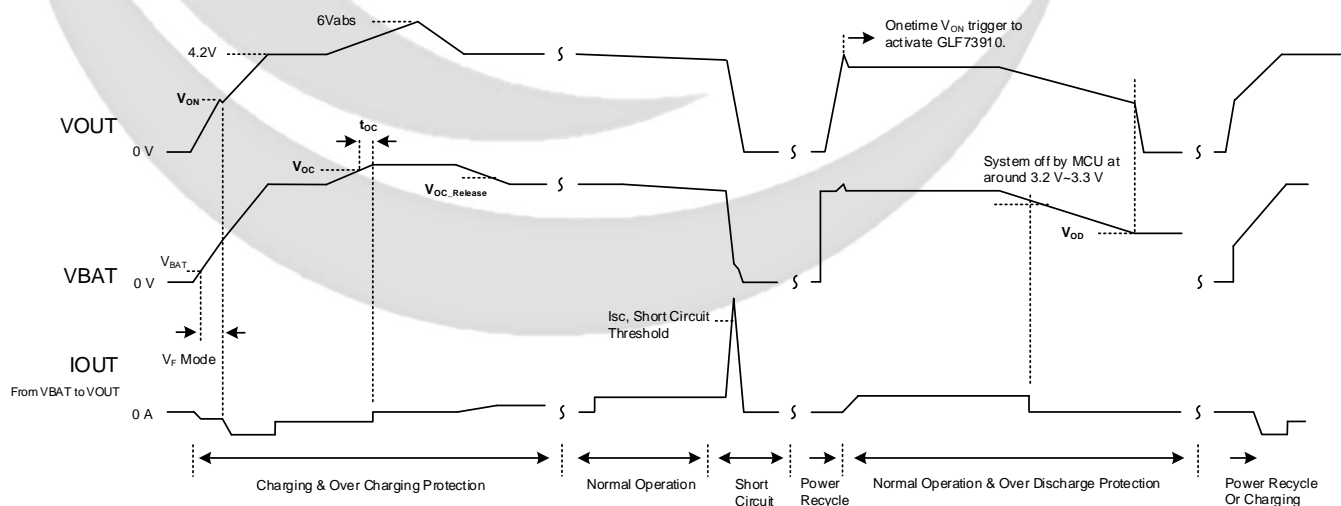

FUNCTIONAL BLOCK DIAGRAM

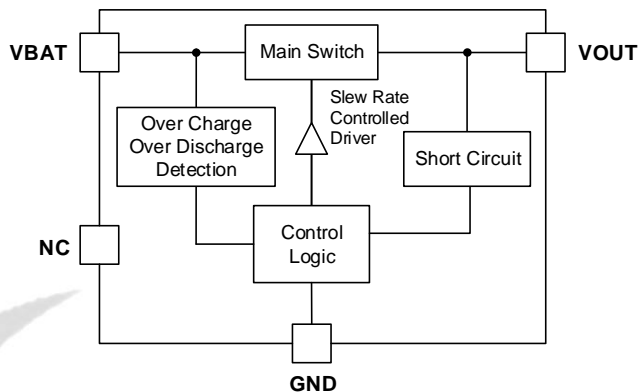

Figure 1. Functional Block Diagram

PIN CONFIGURATION

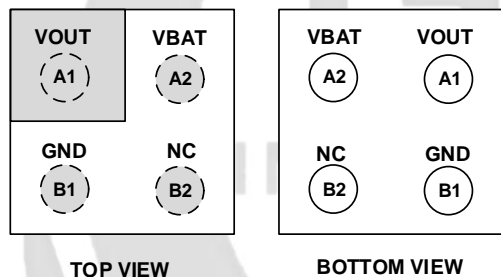

Figure 2. 0.97 mm x 0.97 mm x 0.55 mm WLCSP

PIN DEFINITION

Pin #	Name	Description
A1	VOUT	VOUT pin is connected to the charger output and system load. If the switch is in the off state, applying the appropriate voltage (V_{ON}) to V_{OUT} turns the switch back on.
A2	VBAT	VBAT pin is connected to the positive terminal of a battery pack to monitor the battery voltage. When the V_{BAT} voltage reaches the V_{OD} , the main switch is turned off and maintains the off state to save the battery from discharging.
B1	GND	Ground
B2	NC	No Connection. Leave it open.

ABSOLUTE MAXIMUM RATINGS

Stresses exceeding the absolute maximum ratings may damage the device. The device may not function or be operable above the recommended operating conditions; extended exposure to stresses above the recommended operating conditions may affect device reliability. The absolute maximum ratings are stress ratings only.

Symbol	Parameter	Min.	Max.	Unit
VBAT, VOUT	Each Pin Voltage Range to GND	- 0.3	6	V
I_{BAT}	Switch Continuous Current between VBAT and VOUT		1.5	A
P_D	Power Dissipation at $T_A = 25^\circ\text{C}$		1.2	W
T_{STG}	Storage Junction Temperature	- 65	150	$^\circ\text{C}$
T_A	Operating Temperature Range	- 40	85	$^\circ\text{C}$
θ_{JA}	Thermal Resistance, Junction to Ambient		85	$^\circ\text{C/W}$
ESD	Electrostatic Discharge Capability	Human Body Model, JESD22-A114	8	kV
		Charged Device Model, JESD22-C101	2	

ELECTRICAL CHARACTERISTICS

 Values are at $T_A = 25\text{ °C}$ unless otherwise noted.

Symbol	Parameter	Conditions	Min.	Typ.	Max.	Units	
$V_{BAT(MIN)}$ ⁽¹⁾	Minimum Battery Voltage	Minimum battery voltage for charging	0.4			V	
		GLF73910-AD01C	0				
V_{OC}	Over Charge Detection Voltage	GLF73910-AD01	V_{BAT} increases until switch turns off	4.25	4.35	4.45	V
		GLF73910-AD01C					
		GLF73911-AD01	V_{BAT} at $T_a=55\text{ °C}$ ⁽¹⁾		4.39		
		GLF73910-BD01	V_{BAT} increases until switch turns off	4.40	4.50	4.60	V
					4.54		
V_{OC_HYS}	Over Charge Protection Release Hysteresis	GLF73910-AD01	V_{BAT} decreases and switch turns on		120	mV	
		GLF73910-AD01C					
		GLF73910-BD01					
		GLF73911-AD01	V_{OUT} decreases and switch turns on				
t_{OC}	Over Charge Protection Delay			530		ms	
V_{OD}	Over Discharge Detection Voltage	V_{BAT} decreases until switch turns off	2.72	2.80	2.88	V	
		V_{BAT} decreases until switch turns off, $T_a=55\text{ °C}$ ⁽¹⁾		2.81			
V_{ON}	ON Voltage applied to V_{OUT} to turn on switch	V_{OUT} to turn on switch, $V_{BAT} \geq 3.1\text{ V}$ ⁽¹⁾		3.6		V	
		V_{OUT} to turn on switch, $V_{BAT} \geq 3.1\text{ V}$, $T_a=55\text{ °C}$ ⁽¹⁾		3.6			
V_F	Forward Voltage	From V_{OUT} to V_{BAT} pin, $V_{BAT} < 3.0\text{ V}$		0.4		V	
I_{SC}	Short Circuit Shutdown	$V_{BAT} = 3.6\text{ V}$		0.6		A	
t_{SC}	Short Circuit Delay Time	$V_{BAT} = 3.6\text{ V}$ ⁽¹⁾		0.65		ms	
I_q	Quiescent Current with Switch On	$V_{BAT} = 3.6\text{ V}$, $I_{OUT}=0\text{ mA}$, Switch = ON		0.72		uA	
		$V_{BAT} = 4.2\text{ V}$, $I_{OUT}=0\text{ mA}$, Switch = ON		0.79			
		$V_{BAT} = 4.2\text{ V}$, $I_{OUT}=0\text{ mA}$, Switch = ON, $T_a=55\text{ °C}$ ⁽¹⁾		0.88			
I_{SD}	Shutdown Current from V_{BAT} When Main Switch is Off	GLF73910-AD01	$V_{BAT} = 3.6\text{ V}$, $V_{OUT} = 0\text{ V}$		105	nA	
		GLF73910-AD01C	$V_{BAT} = 2.5\text{ V}$, $V_{OUT} = 0\text{ V}$		70		
		GLF73910-BD01	$V_{BAT} = 2.5\text{ V}$, $V_{OUT} = 0\text{ V}$, $T_a=55\text{ °C}$ ⁽¹⁾		95		
		GLF73911-AD01	$V_{BAT} = 3.6\text{ V}$, $V_{OUT} = 0\text{ V}$		51	nA	
			$V_{BAT} = 2.5\text{ V}$, $V_{OUT} = 0\text{ V}$		35		
			$V_{BAT} = 2.5\text{ V}$, $V_{OUT} = 0\text{ V}$, $T_a=55\text{ °C}$ ⁽¹⁾		58		
R_{ON}	On-Resistance	$V_{BAT}=4.2\text{ V}$, $I_{OUT}= 500\text{ mA}$	$T_a=25\text{ °C}$		34	40	mΩ
			$T_a=55\text{ °C}$ ⁽¹⁾		37		
		$V_{BAT} =3.6\text{ V}$, $I_{OUT}= 500\text{ mA}$	$T_a=25\text{ °C}$		36	42	
			$T_a=55\text{ °C}$ ⁽¹⁾		39		
		$V_{BAT} =3.3\text{ V}$, $I_{OUT}= 500\text{ mA}$	$T_a=25\text{ °C}$		38	45	
t_{OFF}	Turn-Off Time ⁽¹⁾	$C_{OUT}=0.1\text{ }\mu\text{F}$, $R_{OUT}=150\text{ }\Omega$, $V_{OUT} = V_{OD}$ to 0 V		31		us	

Notes: 1. By design; characterized, not production tested.

TYPICAL PERFORMANCE CHARACTERISTICS

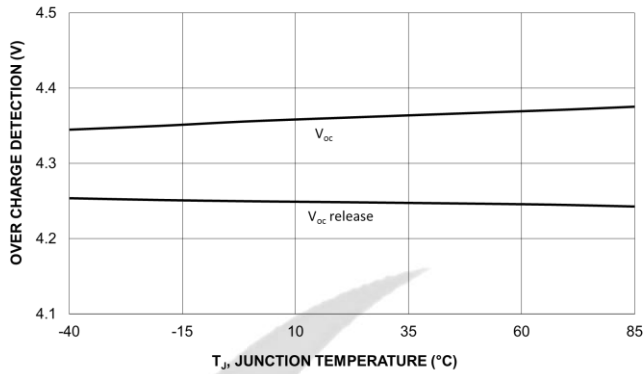

Figure 3. Over Charge Detection Voltage vs. Temperature
GLF73910-AD01, GLF73910-AD01C, GLF73911-AD01

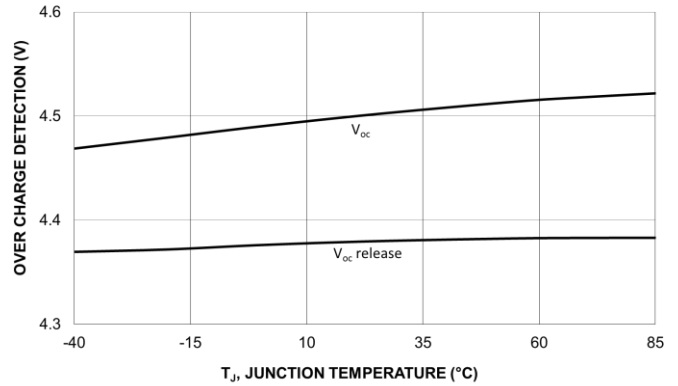

Figure 4. Over Charge Detection Voltage vs. Temperature, GLF73910-BD01

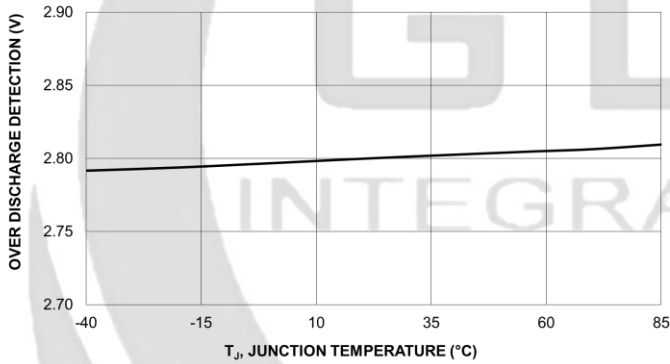

Figure 5. Over Discharge Detection Voltage vs. Temperature

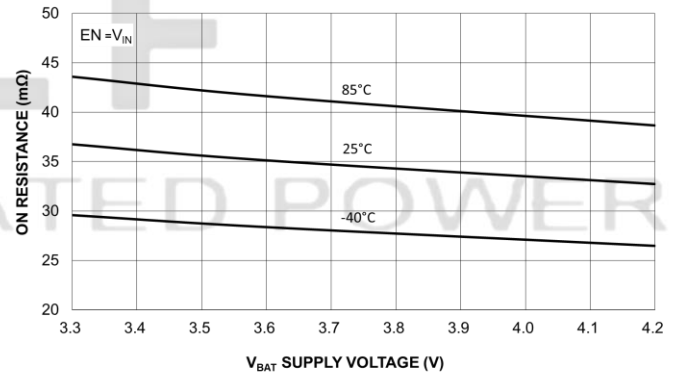

Figure 6. On-Resistance vs. V_{BAT} Supply Voltage

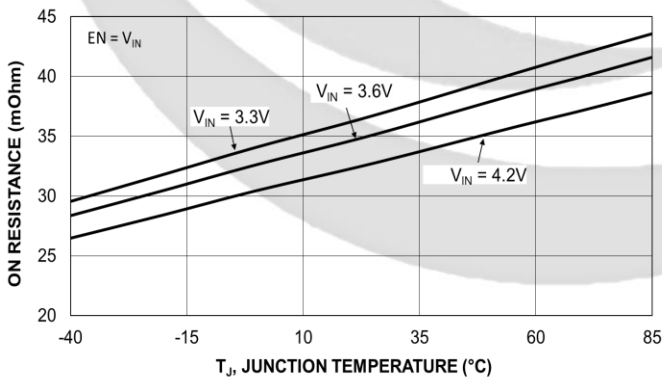

Figure 7. On-Resistance vs. Temperature

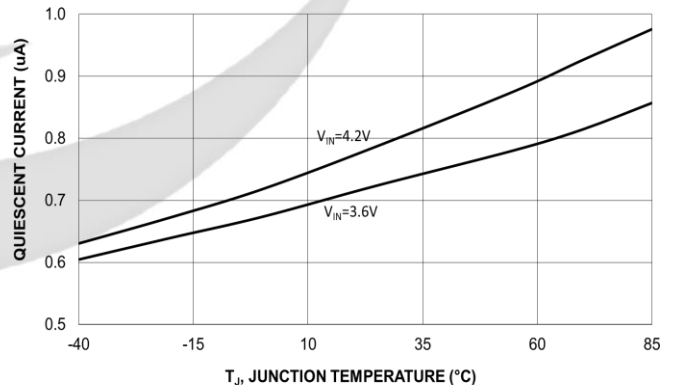

Figure 8. Quiescent Current vs. Temperature

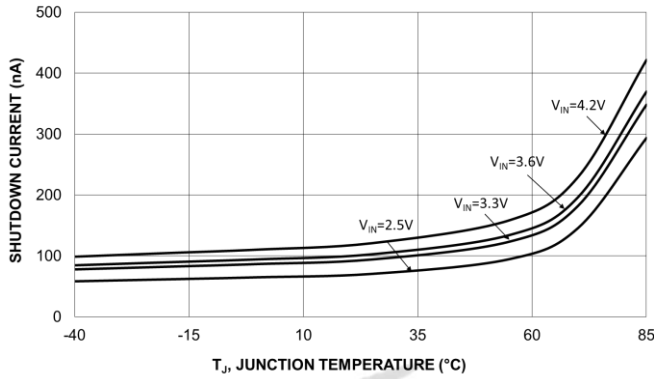

Figure 7. Shutdown Current vs. Temperature
GLF73910-AD01, GLF73910-AD01C, GLF73910-BD01

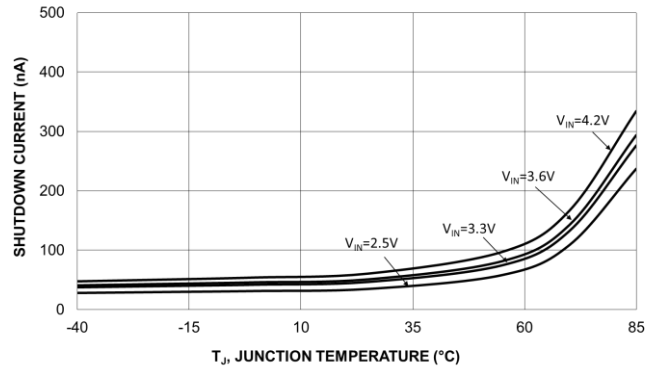

Figure 7. Shutdown Current vs. Temperature
GLF73911-AD01

APPLICATION INFORMATION

The GLF73910 is an IqSmart™ ultra-efficient battery protection switch with the accurate over charge voltage, over discharge voltage, and short circuit protection for lithium-Ion/ Polymer battery safety. The best in class efficiency makes it ideal for the design of hearing devices, wearable devices, and tiny IoT devices.

Activation of Charging and Minimum Battery Charging Voltage

The GLF73910 is activated to turn on the main charging switch only by applying the on voltage (V_{ON}) to the VOUT pin, when a charger IC is enabled. The minimum battery voltage to charge is 0.4 V ($V_{BAT(MIN)}$) when a battery is fully discharged below the over-discharge detection voltage (V_{OD}). With a deeply discharged below 0.4 V, the GLF73910 does not turn on both the charge and discharge paths. During the pre-charge mode, where the battery voltage (V_{BAT}) is between 0.4 V and 2.8 V, the charging current flows through an internal diode (V_F). As the battery voltage increases beyond 3.1 V, the charge and discharge path switches will be fully activated to reduce the voltage drop and save power dissipation during both constant-current and constant-voltage charging modes.

Over Charging Voltage Protection

When the voltage of a battery increases to the over-charge voltage detection level (V_{OC}), the charge path is turned off to stop charging the battery after a preset over-charge detection delay time (t_{OC}) in order to avoid a false trigger. The charging path is not turned off if the battery voltage returns to a voltage less than the detection level within the delay time. The charging path of GLF73910-AD01 and GLF73910-DB01 is turned on again when the battery voltage (V_{BAT}) decreases below the over-charge voltage release level ($V_{OC} - V_{OC_HYS}$). In the GLF73911-AD01, the charge and discharge path close fast once a load is connected and the VOUT falls to the over-charge voltage release level.

Over Discharging Voltage Protection

When the voltage of a battery decreases to the over-discharge detection voltage level, the GLF73910 discharging path is turned off consuming an ultra-low leakage current to save the battery. The GLF73910 remains in the off state until a higher voltage is applied to the VOUT pin.

Short Circuit Protection

When the discharge current from the battery exceeds the short circuit detection level (I_{SC}), the discharging path of the GLF73910 will be turned off after a preset delay time (t_{SC}) in order to avoid a false detection. After the short circuit protection event, the GLF73910 maintains in the off state and needs a power recycle of a system to apply V_{ON} to VOUT pin in order to be reactivated.

Input and Output Capacitors

Input and output capacitors are not required for GLF73910 operation. However, a 0.1uF capacitor is recommended to be placed close to the VBAT and VOUT pins in order to mitigate any unexpected electrical noise or the transient voltage peak caused by a hot-plugging voltage source.

Board Layout

All traces should be as short as possible to minimize parasitic inductance effects. Wide traces for VBAT, VOUT, and GND will help reduce voltage drops, and parasitic effects during dynamic operation as well as improve the thermal performance at high load currents.



PACKAGE OUTLINE

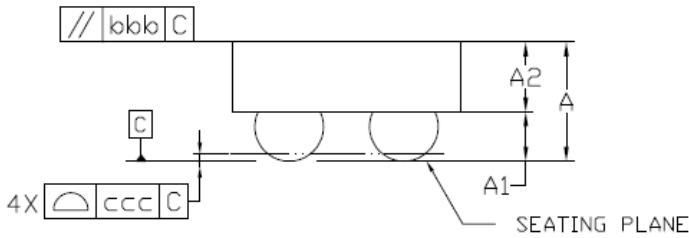
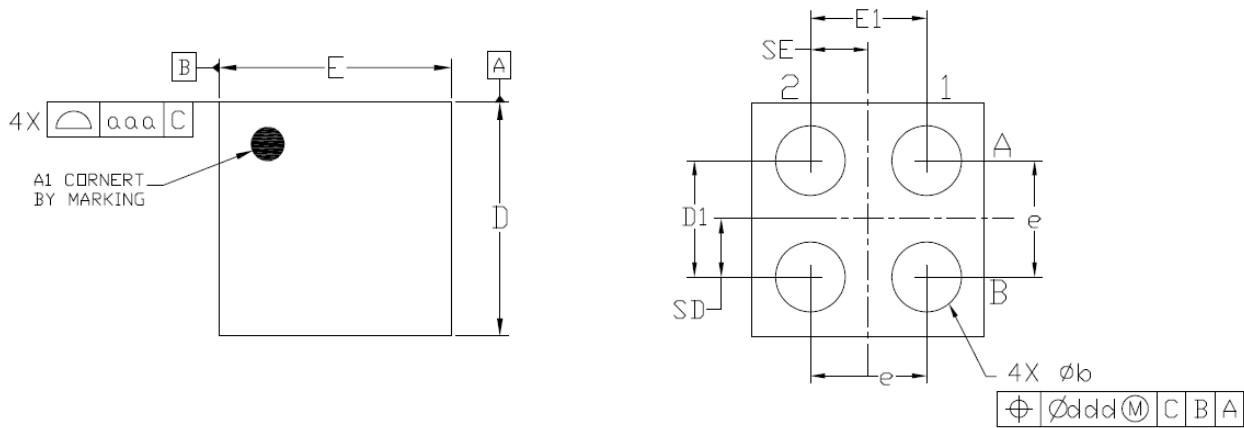

Dimensional Ref.			
REF.	Min.	Nom.	Max.
A	0.500	0.550	0.600
A1	0.225	0.250	0.275
A2	0.275	0.300	0.325
D	0.960	0.970	0.985
E	0.960	0.970	0.985
D1	0.450	0.500	0.550
E1	0.450	0.500	0.550
b	0.260	0.310	0.360
e	0.500 BSC		
SD	0.250 BSC		
SE	0.250 BSC		
Tol. of Form&Position			
aaa	0.10		
bbb	0.10		
ccc	0.05		
ddd	0.05		

Notes

1. ALL DIMENSIONS ARE IN MILLIMETERS (ANGLES IN DEGREES).
2. DIMENSIONING AND TOLERANCING PER ANSI Y14.5M-1994.

TAPE AND REEL INFORMATION

REEL DIMENSIONS

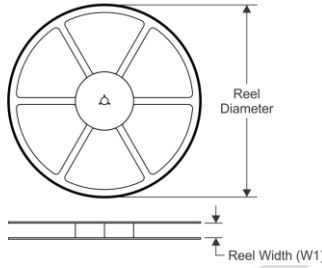

QUADRANT ASSIGNMENTS PIN 1 ORIENTATION TAPE

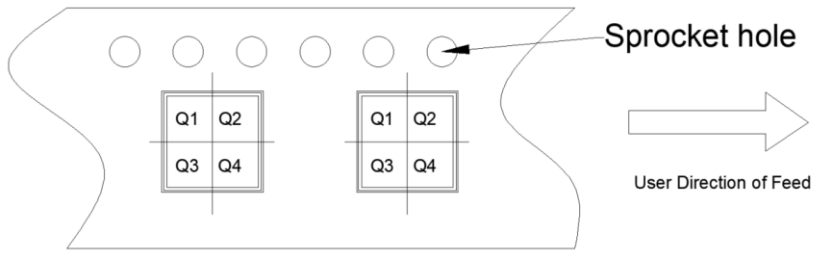

TAPE DIMENSIONS

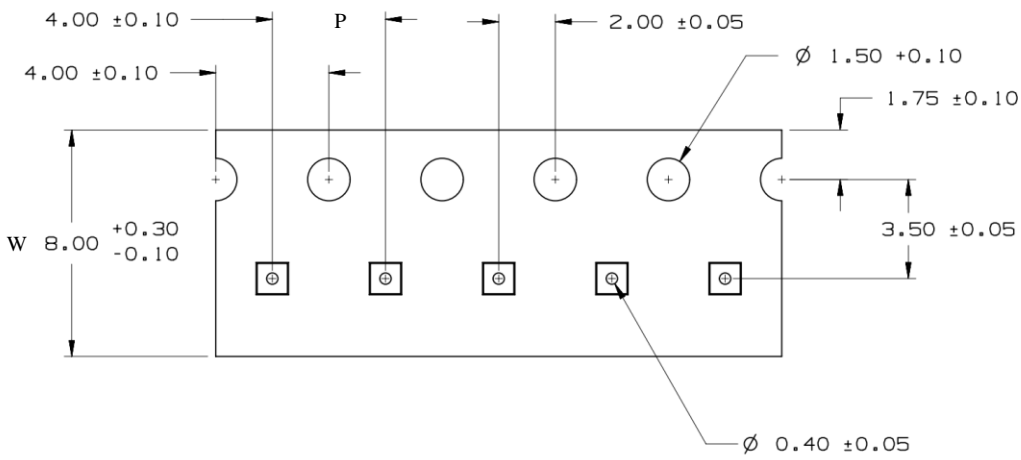

OWER

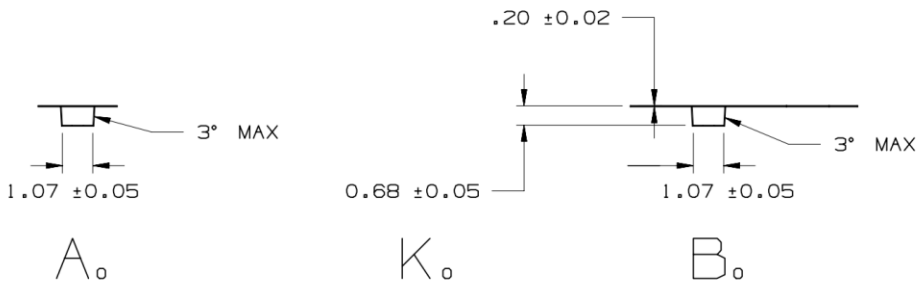

Device	Package	Pins	SPQ	Reel Diameter(mm)	Reel Width W1	A0	B0	K0	P	W	Pin1
GLF73910-AD01	WLCSP	4	3000	180	9	1.07	1.07	0.68	4	8	Q1
GLF73910-AD01C	WLCSP	4	3000	180	9	1.07	1.07	0.68	4	8	Q1
GLF73910-BD01	WLCSP	4	3000	180	9	1.07	1.07	0.68	4	8	Q1
GLF73911-AD01	WLCSP	4	3000	180	9	1.07	1.07	0.68	4	8	Q1

Remark:

- A0: Dimension designed to accommodate the component width
- B0: Dimension designed to accommodate the component length
- C0: Dimension designed to accommodate the component thickness
- W: Overall width of the carrier tape
- P: Pitch between successive cavity centers

SPECIFICATION DEFINITIONS

Document Type	Meaning	Product Status
Target Specification	This is a target specification intended to support exploration and discussion of critical needs for a proposed or target device. Spec limits including typical, minimum, and maximum values are desired, or target, limits. GLF reserves the right to change limits at any time without warning or notification. A target specification in no way guarantees future production of the device in question.	Design / Development
Preliminary Specification	This is a draft version of a product specification. The specification is still under internal review and subject to change. GLF reserves the right to change the specification at any time without warning or notification. A preliminary specification in no way guarantees future production of the device in question.	Qualification
Product Specification	This document represents the anticipated production performance characteristics of the device.	Production

DISCLAIMERS

Information in this document is believed to be accurate and reliable, however GLF assumes no liability for errors or omissions. Device performance may be impacted by testing methods and application use cases. Users are responsible to independently evaluate the applicability, usability, and suitability of GLF devices in their application. In no case will GLF be liable for incidental, indirect, or consequential damages associated with the use, mis-use, or sale of its product. Customers are wholly responsible to assure GLF devices meet their system level and end product requirements. GLF retains the right to change the information provided in this data sheet without notice.