

GLF4020

High Efficiency Power Multiplexer Switch with Manual Input Selection

DESCRIPTION

The GLF4020 is an integrated power multiplexer switch with dual independent power switches connected to a single output pin to enable seamless transition between two input sources.

The GLF4020 provides a manual selection mode by the combination of the logic input pins of EN and SEL. The GLF4020 features an ultra-efficient I_Q Smart™ technology that offers quiescent current (I_Q) and shutdown current (I_{SD}) in the industry. Low R_{ON} reduces conduction losses while low I_Q and I_{SD} solutions help designers to reduce parasitic leakage current, improve system efficiency, and increase battery lifetime.

The GLF4020 blocks any cross-conduction current between two input power sources. When the switch is disabled, the GLF4020 prevents the reverse current to the input source from the output at any higher V_{out} than V_{in} condition.

FEATURES

- Two-Input and Single-Output Power Multiplexer Switch
- Manual Input Selection Mode
- Supply Voltage Range:
2.5 V to 6.5 V
7 V_{abs} Max
- R_{ON} : 92 mΩ Typ. at 6.5 V_{IN1} or V_{IN2}
105 mΩ Typ. at 4.5 V_{IN1} or V_{IN2}
- 2 A Continuous Output Current Capability Per Channel
- Ultra-Low Supply Current at Operation
 I_Q : 4 μA Typ at 6.5 V_{IN}
- Ultra-Low Stand-by Current
 I_{SD} : 6 nA Typ at 6.5 V_{IN}
- Smart Control Pins
 I_{EN} and I_{SEL} : 3 nA Typ at V_{EN} or V_{SEL} > V_{IH}
 R_{EN} and R_{SEL} : 500 kΩ Typ
- No Cross Conduction Between Two Inputs
- Reverse Current Blocking when Disabled
- Operating Temperature Range:
-40 to 85 °C
- HBM: 6 kV, CDM: 2 kV

PRODUCT TABLE

Eval Board Ordering Info	Part Number	Top Mark	RON at 6.5 V _{IN}	Output Current, I _{OUT}	Ultra-low IQ at 6.5V _{IN}
EV019-GLF4020	GLF4020-T2G7	DP	92 mΩ	2 A	4 μA

EVALUATION BOARD & DEVICE PACKAGE

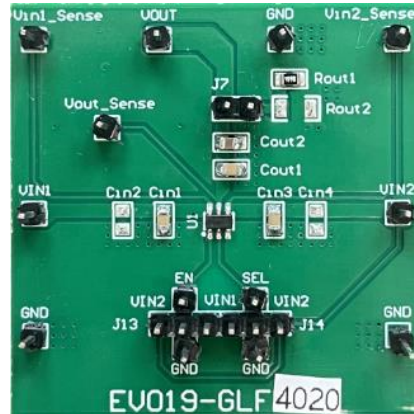

PIN CONFIGURATION AND DEFINITION

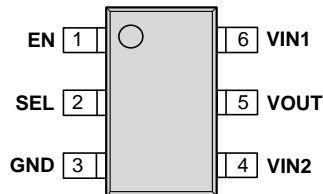

Top view

SOT23-6L

Pin #	Name	Description
1	EN	Enable to control the switch. Do not leave the EN pin floating.
2	SEL	Input Source Selection. Do not leave the SEL pin floating.
3	GND	Ground
4	VIN2	Switch Input 2
5	VOUT	Switch Output
6	VIN1	Switch Input 1

QUICK START GUIDE

The evaluation board EV019 is easy to set up to evaluate the performance of GLF4020.

1. Preset the input power supply to the desired voltage between 2.5 V to 6.5 V.
2. The load resistor, Rout1=499 Ω , has been populated on the top of the PCB board. Short the J2 to use the Rout1 or Rout2 which is not populated. To increase the output current, connect an electronic load to VOUT and GND. The output current for the GLF4020 is rated for 2 A maximum output continuous current per each channel. Please ensure this absolute maximum is not exceeded.
3. Connect the positive and negative terminals of the input power supply to VIN and GND respectively. Vin1_Sense, Vin2_Sense, and Vout_Sense can be used for measurement point.
4. The input source selection function is set by the combination of SEL and EN. See Table 1 below. The SEL pin and the EN pin is connected to one of Input sources by J13 and J14 respectively.
5. Turn on the input power supply.
6. Note : The GLF4020 has an internal EN and SEL pull-down resistor to ensure the part is in a defined state.

Table 1. Truth Table of Input Source Selection

SEL	EN	Function	VOUT
0	0	Both switches are off	High-Z
1	0	Only VIN1 is selected	VIN1
1	1	Only VIN2 is selected	VIN2

TEST SETUP

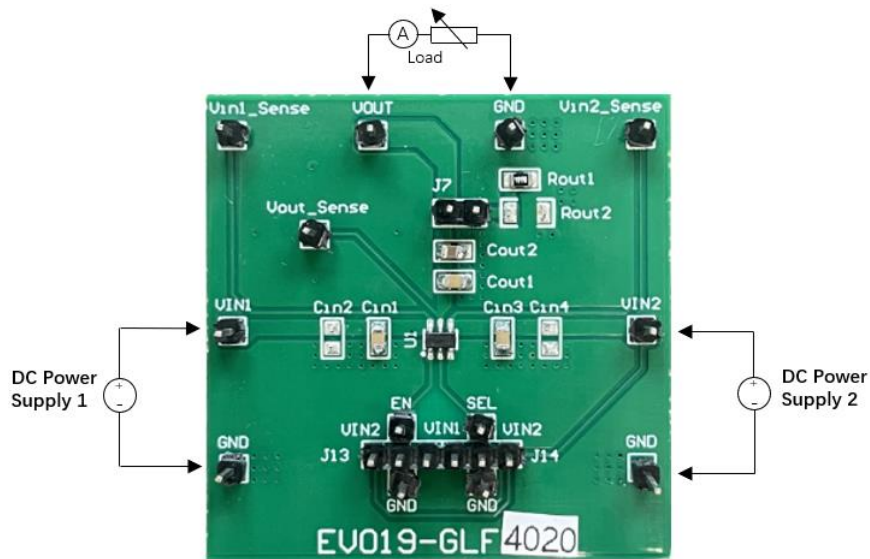

SCHEMATIC

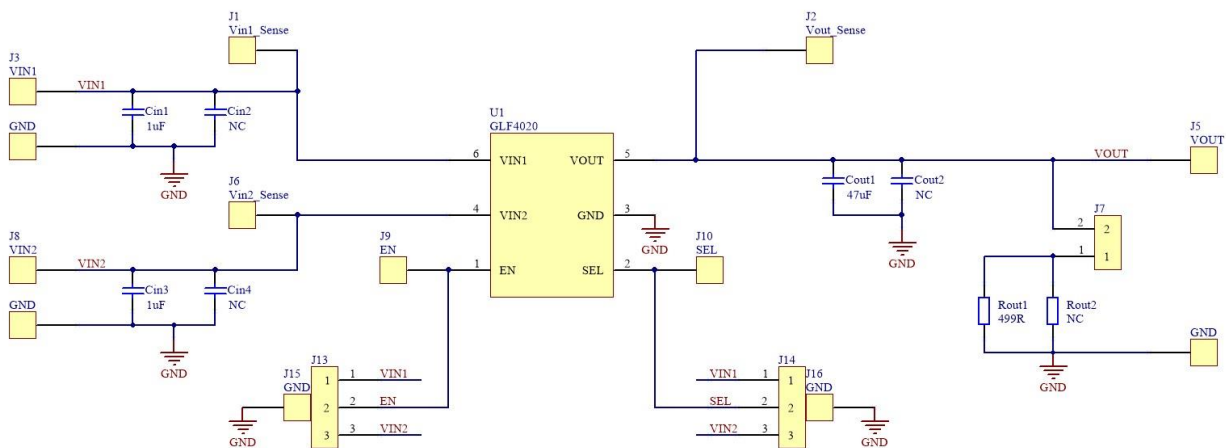

BILL OF MATERIALS

Qty	Reference	Value	Part Description	Manufacturer/Part Number
1	U1	GLF4020	GLF4020	GLF Integrated Power
2	Cin1, Cin3	1 μ F	Cap., X7R, 50V, 10% 0805	YAGEO CC0805KKX7R9BB105
2	Cout1, Cout2	47 μ F	Cap., X5R, 10V, 20% 0805	TDK C2012X5R1A476M125AC
1	Rout1	499 Ω	Output Resistor	YAGEO RC0805FR-07499RL
2	Cin2, Cin4	-		Not populated
1	Rout2	-		Not populated
3	J7, J13, J14	Jumper	Jumper	

PRINTED CIRCUIT BOARD LAYOUT

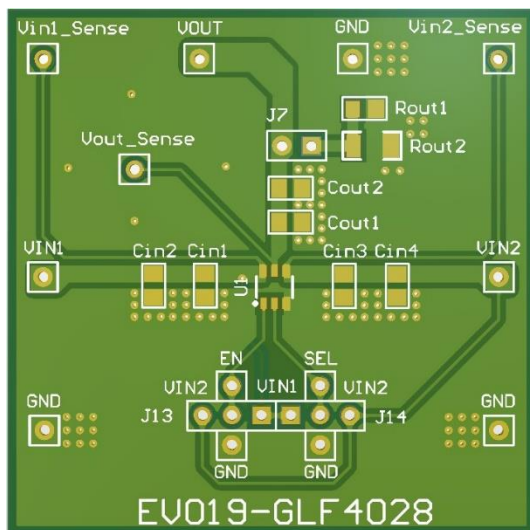

Fig 1. Top Layer

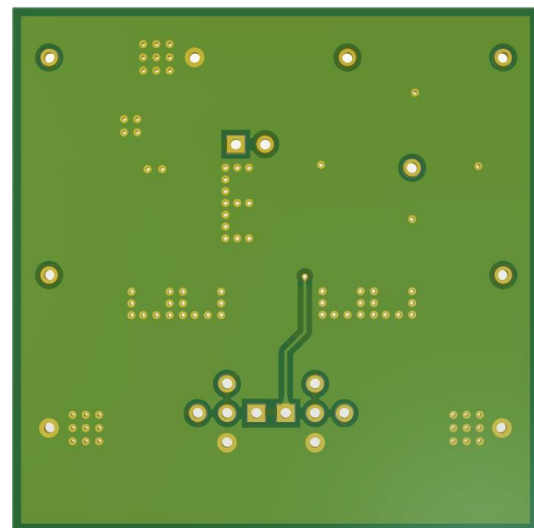

Fig 2. Bottom Layer

NOTICE: The evaluation board provided by GLF Integrated Power is intended for use for ENGINEERING DEVELOPMENT, OR EVALUATION PURPOSES ONLY and is not for any commercial use. The user assumes all responsibility and liability for proper and safe handling of the goods.